

## Influence of the difference between implant body and screw materials on abutment screw loosening

Ryusuke SHINOHARA<sup>1</sup>, Kazuhiko UEDA<sup>2</sup> and Fumihiko WATANABE<sup>1,2</sup>

<sup>1</sup> Functional Occlusal Treatment, Graduate School of Life Dentistry at Niigata, The Nippon Dental University 1-8 Hamaura-cho, Chuo-ku, Niigata 951-8580, Japan

<sup>2</sup> Department of Crown and Bridge Prosthodontics, School of Life Dentistry at Niigata, The Nippon Dental University 1-8 Hamaura-cho, Chuo-ku, Niigata 951-8580, Japan

Corresponding author, Ryusuke SHINOHARA; E-mail: rshinohara1022@ngt.ndu.ac.jp

The purpose of this study was to investigate how differences in dental implant and screw materials affected screw loosening. Screws (pure titanium; Ti4S, titanium alloy; TiAS), blocks (Y-TZP; ZrB, pure titanium; Ti4B) and plates (Y-TZP; ZrP), representing abutment screws, implant bodies and superstructures, respectively, were used. Plates were fastened to blocks by screws using a torque of 20 N·cm, and the loosening torque was measured after cyclic loading. Tests were performed on 13 specimens per group, with four groups for loading at the eccentric point (9 mm from screw center) and one group at the centric point (3 mm from screw center). In eccentric point tests, Ti4S screws led to significantly more loosening than TiAS screws ( $p < 0.01$ ). The block material had no effect. For ZrB-Ti4S, there was no difference in loosening before and after the centric point tests. More loosening occurred for eccentric point than for centric point tests ( $p < 0.05$ ).

**Keywords:** Dental implant, Zirconia dental implant, Cyclic loading test, Abutment screw loosening, Difference of materials

### INTRODUCTION

Oral implant treatments are finding more and more clinical applications due to their high rate of success and predictability. However, many complications have also been reported. Goodacre *et al.*<sup>1</sup> reported that mechanical complications include abutment screw loosening, and fracture of the abutment screw, abutment, superstructure and implant body. Avivi-Arber and Zarb reported that abutment screw loosening is the most frequent mechanical complication<sup>2</sup>. It reportedly causes component failure, peri-implantitis, and other issues that in some cases lead to serious complications<sup>3-5</sup>. On the incidence of abutment screw loosening, Jemt *et al.*<sup>6,7</sup> reported that of single-tooth restoration cases, 55.7% experience abutment screw loosening within 1 year after the superstructure has been set<sup>6</sup>, with 24.2% after 2 weeks and 5.7% after 4 weeks<sup>7</sup>.

Kose *et al.*<sup>8</sup> showed that one of the factors causing abutment screw loosening is the force applied to the superstructure. It has been reported that complex forces can be applied to the superstructure in dental implants, including vertical, torsional and bending forces<sup>9</sup>. It is thought that abutment screw loosening is more likely to occur in a superstructure with a cantilever due to the more complex forces present<sup>10</sup>.

Recently, zirconia has been used clinically as an implant material due to allergy-related and esthetic reasons<sup>11</sup>. Most zirconia implants that are currently fabricated are the one-piece type, although a two-piece type in which the implant body and abutment

are divided has also been fabricated<sup>11</sup>. In the latter type of implant, the abutment is connected to the implant by cementing<sup>12,13</sup> or by the use of a screw. The biocompatibility and mechanical strength of zirconia implants have been the subject of several studies<sup>11,14,15</sup>. However, although there has been extensive research on abutment screw loosening for titanium implants<sup>3,4,8-10,16,17</sup>, to our knowledge there are no reports for two-piece zirconia implants connected by screws.

The purpose of this study is to investigate the influence of differences in implant body and abutment screw materials on screw loosening under cyclic loading tests using simulated implant prosthesis models.

### MATERIALS AND METHODS

#### *Test specimens*

Specimens consisted of three components: a block, representing an implant body; a screw, representing the abutment screw; and a plate, representing a superstructure with a cantilever shape (Figs. 1 and 2). The blocks were fabricated with a U-shape and dimensions of 16×5×15 mm. Thirty nine blocks were made of yttria-stabilized tetragonal zirconia polycrystal (ZrB), and 26 were made of ASTM grade 4 pure titanium (Ti4B). The screws had a diameter of 2.5 mm, a length of 12 mm, including a 3.5-mm threaded portion. The diameter and thread size conformed to ISO-68-1 and JIS B 0205, with M2×0.4. Thirty nine screws were made of ASTM grade 4 pure titanium (Ti4S), and 26 were made of titanium alloy Ti-6Al-4V (TiAS). The plates had dimensions of 10×22×7 mm, and 65 plates were fabricated using yttria-stabilized tetragonal zirconia

Color figures can be viewed in the online issue, which is available at J-STAGE.

Received Jan 22, 2018; Accepted May 23, 2018

doi:10.4012/dmj.2018-023 JOI JST.JSTAGE/dmj/2018-023

polycrystal (ZrP). The shape was extended to one side from the screw hole. The specimens were fabricated by NANTOH, Numazu, Japan.

#### Experimental procedure

The experiments were performed on 13 specimens from each of the four groups ZrB-Ti4S, ZrB-TiAS, Ti4B-Ti4S, and Ti4B-TiAS, for a total of 52 specimens. On ZrB-Ti4S, Further experiments were performed on 13 specimens from the ZrB-Ti4S group at a different loading point. After the block was fixed to a cyclic loading machine (Servopulser, Shimadzu EHF-FB, Shimadzu, Kyoto, Japan), a digital torque meter (HDM-5 HIOS, Chiba, Japan) was used to tighten the screw using a torque of 20 N·cm through the plate and into the block. The specimen was then allowed to stand for 10 min, following which the loosening torque was measured. This was

repeated twice, and the tightening and loosening torque values measured the second time were taken as the tightening torque before the cyclic loading test ( $TT1$ ) and the loosening torque before the cyclic loading test ( $LT1$ ), respectively. The measured values were used to calculate the loosening torque ratio before the test ( $LTR1$ ) using:

$$LTR1 = \frac{TT1 - LT1}{TT1} \times 100 (\%) \quad (1)$$

After  $LT1$  was measured, the screw was tightened again using a torque of 20 N·cm, to perform a cyclic loading test under a load of 100 N, a frequency of 2 Hz, and 100,000 cycles. The tightening torque in this step was taken as the tightening torque immediately before the cyclic loading test ( $TT2$ ). As shown in Figs. 3 and 4, the cyclic loading tests were performed on two different loading points. For each of the four groups (ZrB-Ti4S, ZrB-TiAS, Ti4B-Ti4S, Ti4B-TiAS), 13 specimens were tested at a point referred to as the eccentric point, located 9 mm from the center of the screw hole to one side. This is labeled point (a) in Fig. 3 and is shown in the photograph in Fig. 4(a). In order to investigate the effect of the loading point, 13 specimens in group ZrB-Ti4S were also tested at a point referred to as the centric point, located 3 mm from the center of the screw hole towards the front of the cyclic loading machine. This is labeled point (b) in Fig. 3 and is shown in the photograph in Fig. 4(b).

After the tests were finished, the loosening torque was measured by a digital torque meter. This was taken as the loosening torque after the cyclic loading test ( $LT2$ ). The measured values were used to calculate the loosening torque ratio after the cyclic loading test ( $LTR2$ ) using:

$$LTR2 = \frac{TT2 - LT2}{TT2} \times 100 (\%) \quad (2)$$

The calculated  $LTR1$  and  $LTR2$  values were statistically analyzed using a statistics software package (Ekuseru-toukei 2013, SSRI, Tokyo, Japan), with a paired  $t$ -test

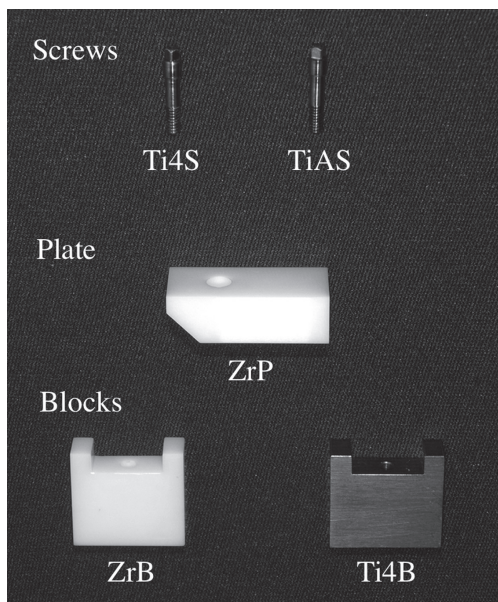

Fig. 1 Test specimen. Screws (left: Ti4S right: TiAS), Plate (ZrP), Blocks (left: ZrB right: Ti4B).

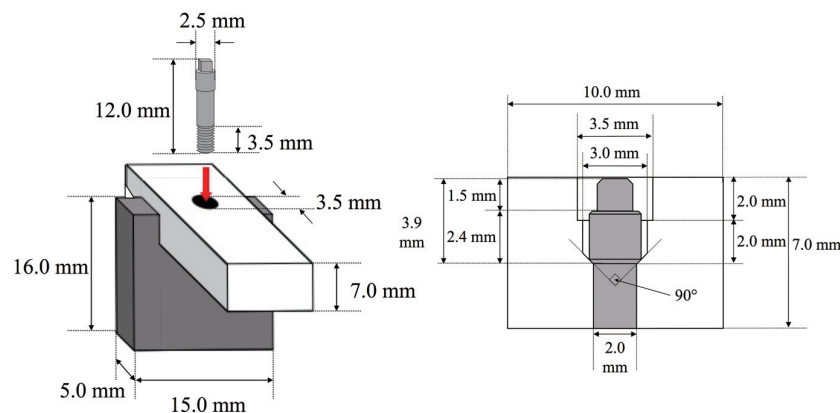

Fig. 2 Diagram of specimen.

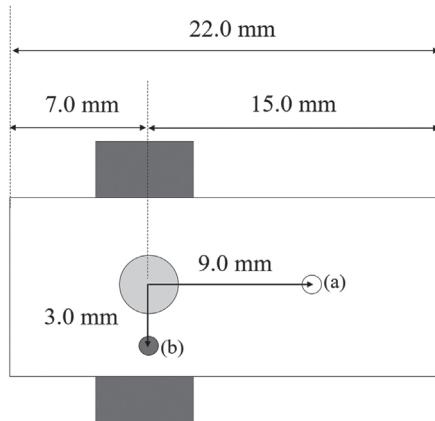

Fig. 3 Schematic on loading point (a) Eccentric point (b) Centric point.

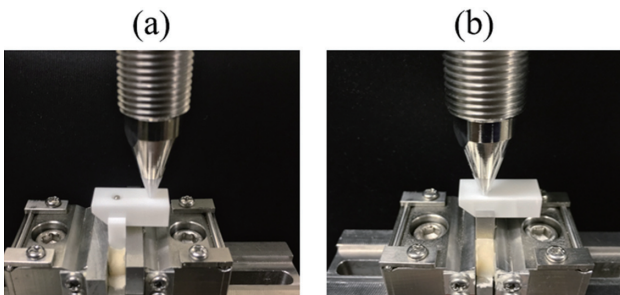

Fig. 4 Test specimens fixed to cyclic loading machine (a) Eccentric point (b) Centric point.

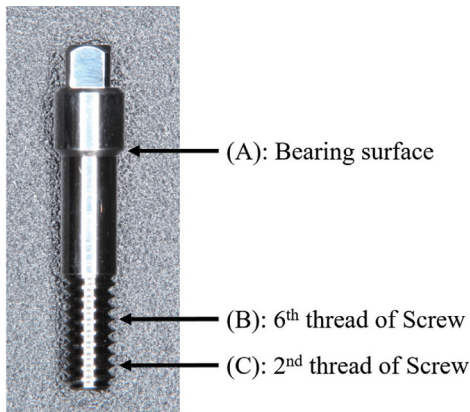

Fig. 5 SEM observation sites.

for the difference in loosening torque ratio before and after the cyclic loading test, a two-way ANOVA and Tukey's multiple comparison for the difference between materials, and a one-way ANOVA and Tukey's multiple comparison for the difference between loading points. The screws from each group were observed by scanning electron microscopy (SEM; JSM6330F, JEOL, Tokyo, Japan) after each test, at a magnification of 200×. Screws were observed before being tightened, before the cyclic loading test (*LT1*) and after the cyclic loading test

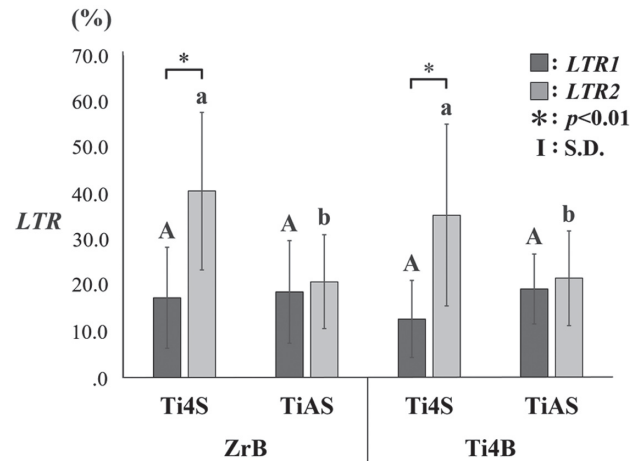

Fig. 6 Loosening torque ratio at the eccentric point before and after test.

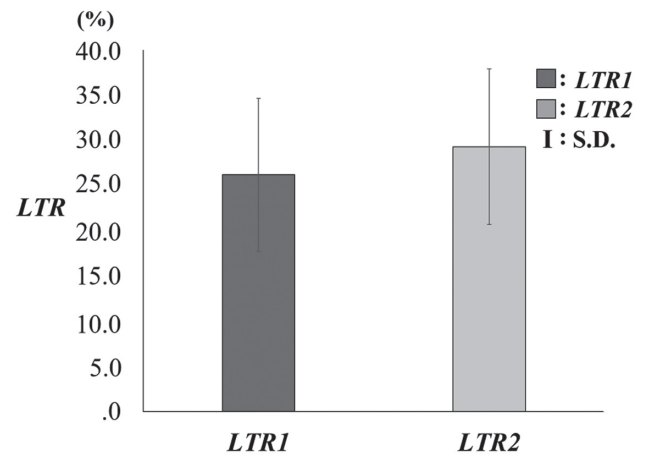

Fig. 7 Loosening torque ratio at the centric point before and after test.

(*LT2*), in order to identify deformation or displacement. As shown in Fig. 5, there were three observation sites on the screws: (A) the connection between the plate and the screw, (B) the 4th thread from the top of the screw and (C) the 8th thread from the top of the screw.

RESULTS

*Loosening torque ratio before cyclic loading test (LTR1)*  
As shown in Fig. 6 for *LTR1*, the results of the two-way ANOVA and Tukey's multiple comparison did not show significant differences between any of the groups before the cyclic loading test. The groups fastened with Ti4S screws tended to have a lower loosening torque ratio than those fastened with TiAS screws (Ti4S: 15.00±9.82%, TiAS: 18.92±9.35%). The group with the highest loosening torque ratio was Ti4B-TiAS, at 19.16±7.58%.

*Loosening torque ratio after cyclic loading test (LTR2)*  
As shown in Fig. 6 for *LTR2*, all groups showed an

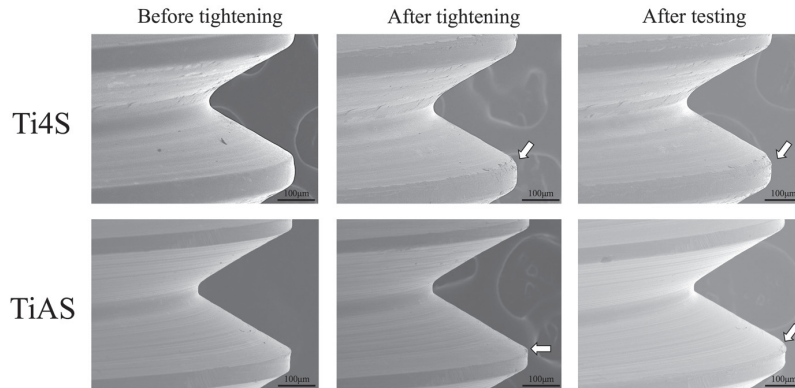

Fig. 8 SEM images at C-point for Ti4S and TiAS after tightening to ZrB and test at the eccentric point.

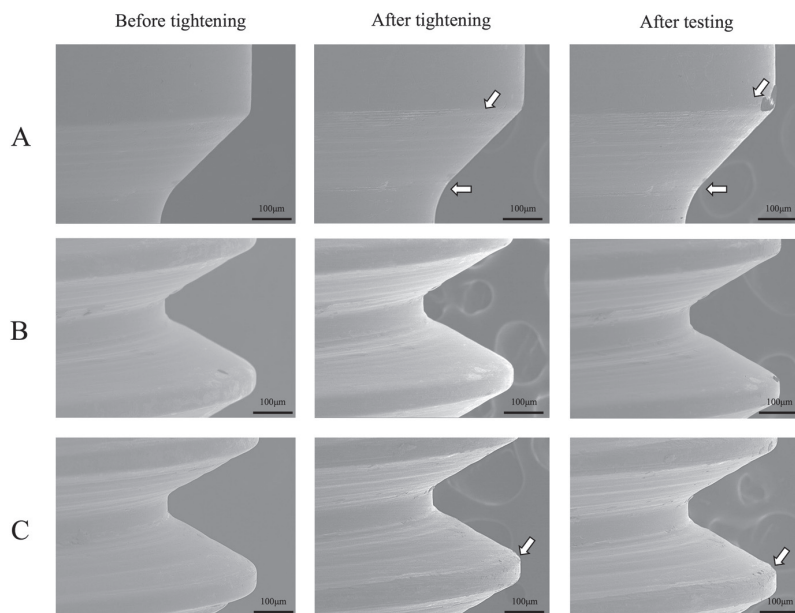

Fig. 9 SEM images of each observation point during test at the centric point for ZrB-Ti4S.

increase in loosening torque ratio after the cyclic loading test. The results of the two-way ANOVA and Tukey's multiple comparison showed highly significant differences between screw materials ( $p < 0.01$ ). No differences were observed between block materials, however. The group that showed the highest loosening torque ratio was ZrB-Ti4S, at  $40.48 \pm 17\%$ .

The paired  $t$ -test showed a significant difference in loosening torque ratio before and after tests in the groups fastened with Ti4S screws ( $p < 0.01$ ). Groups fastened with TiAS screws did not show a significant difference in loosening torque ratio before and after the test.

#### Difference in loading point

Figure 7 shows the test results at the centric point for ZrB-Ti4S. Although the loosening torque ratio appears to increase after the test, the results of the paired  $t$ -test showed no significant difference. The results of the one-

way ANOVA and Tukey's multiple comparison for *LTR2* at each loading point showed a significantly higher loosening torque ratio when the test was performed at the eccentric point ( $p < 0.05$ ).

#### Observations by SEM

Figure 8 shows SEM images at the C-point for Ti4S and TiAS screws before and after tightening to ZrB, and after testing at the eccentric point. After tightening, both screws exhibited more scratches on the mating surface, together with edge wear (Fig. 8 arrows), compared to before tightening. Similar results were found for the A-point. However, the extent of this damage did not change after the test. TiAS screws tended to have less damage than Ti4S screws. No differences were observed at the B-point. As shown in Fig. 9, results similar to those for the eccentric point were also found for ZrB-Ti4S when the test was done at the centric point.



DISCUSSION

Test conditions and methods

Cyclic loading tests have been used in biomechanical studies on implants<sup>18)</sup>, although the conditions varied with each study. The present study considered the situation just after the superstructure had been set and then after one month<sup>9)</sup> of standard chewing (assuming 100,000 cycles at a frequency of 2 Hz<sup>19)</sup>). The loading points used were those shown in Fig. 4, and were chosen based on a report by Fernandes *et al.*<sup>20)</sup> The eccentric point was intended to simulate contact at the center of the occlusal surface of the mandibular second premolar tooth and the center of the occlusal surface of the mandibular first molar. The centric point was intended to simulate contact at the center of the occlusal surface of the mandibular first molar, as close to the screw as possible without directly applying an external force to the screw. Regarding loading, it has been reported that a superstructure with a cantilever should preferably be infraoccluded 100 μm more than a normal one<sup>21)</sup>. Therefore, the tests were performed under a load of 100 N, which is lower than the mean value of 143 N reported by Mericske-Sterm and Zarb regarding the occlusal force applied to the implant superstructure<sup>22)</sup>.

The tightening torque for the abutment screw varies depending on the screw material and on the manufacturer<sup>23)</sup>. In the present study, we used a triangular screw head that was M2×0.4, and a tightening torque of 20 N·cm. Yoshida performed a torsional fracture test using M2×0.4 pure titanium micro-screws, and reported that the torsional strength was 54 N·cm<sup>24)</sup>. Moraes *et al.* also reported that when two sets of cylinders made of gold and Ni-Cr-Br were tightened onto an abutment with titanium screws at a tightening torque of 10 or 20 N·cm, the group tightened at 20 N·cm showed less of a gap<sup>25)</sup>. Based on these reports, the tightening torque in the present study was set to 20 N·cm.

There are many kind of connection between implant body and abutment. Katsuta and Watanabe<sup>9)</sup> reported there were differences between the type of connection. Therefore, the shape of block is determined as U-shape to except these effects and to simplify the design of connection.

Kohal *et al.*<sup>26)</sup> performed cyclic loading tests using identically-shaped two-piece zirconia and titanium implants with internal abutment connections, and reported that fractures occurred in the neck of the implant body. They concluded that it would be difficult to use two-piece zirconia implants in clinical practice. Therefore, basic research was performed with specimens intended to simulate screw-retained superstructures with a cantilever set onto a block, representing an implant body.

Loosening torque ratio before cyclic loading test (LTR1)

The loosening torque was measured by allowing the specimen to stand for 10 min after tightening the screw, loosening it, tightening it again, and then measuring the loosening torque, following the technique reported by

Katsuta and Watanabe<sup>9)</sup> and Kourtis *et al.*<sup>17)</sup>. This takes into account the settling effect of the mating surface. The results of the two-way ANOVA did not show any significant differences between materials. This suggests that under the present conditions, no external force was applied to the screws.

Loosening torque ratio after cyclic loading test (LTR2)

The results of tests at the eccentric point showed significant differences only between screw materials. The results of the *t*-test showed a significant difference before and after tests in the groups fastened with grade 4 pure titanium screws, with ZrB-Ti4S showing the highest loosening torque ratio. In terms of the Vickers hardness of the materials used in this study, it is reportedly 177 Hv for grade 4 pure titanium, 256 Hv for Ti-6Al-4V, and 1356 Hv for Y-TZP<sup>5)</sup>, and these were the combinations used in the study that showed the greatest difference in hardness between materials. Therefore, cyclic loading tests were also performed at the centric point. The results of the paired *t*-test showed no significant difference in the loosening torque ratio before and after the tests. On the other hand, the results of the one-way ANOVA and Tukey’s multiple comparison showed that the loosening torque ratio was significantly higher when the tests were performed at the eccentric point than at the centric point. A superstructure with a cantilever is subjected to tensile forces<sup>12)</sup>. Yanagida *et al.* showed that the maximum tensile force for an abutment screw with a diameter of 1.8 mm was 2,881±22 N, and simultaneously performed a geometric analysis<sup>27)</sup>. When the tensile force applied to the screws in the present study was calculated using the same technique, it was determined to be around 260 N (Fig. 10). If this force is applied repeatedly to the screw, it will cause a failure of the connection between the plate and the screw (SEM observation site A), which is the upper connection of the screw, and the thread joining section (SEM observation site C), which is the lower connection, each become a retaining section. When the tensile force is applied to the screw, elastic deformation occurs in the entire screw to over the elastic region. When the load is removed, due to the slight stretching of the screw, a small separation occurs between the upper and lower connection surfaces

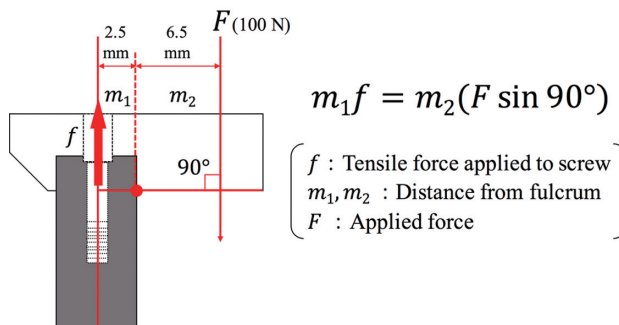

Fig. 10 Schematic and formula used for geometric analysis.

and the tightening force of the screw is reduced, which results in loosening of the screw. According to Osman and Swain, grade 4 pure titanium has a yield strength of 483 MPa, while Ti-6Al-4V has a higher yield strength, at 860 MPa<sup>28)</sup>, and this may cause loosening to occur less easily with TiAS, as it was less readily deformed in the cyclic loading tests at the eccentric point. At the centric point, however, loading caused a compressive force to be applied to the block and plate, opening a separation between the screw contact surface, resulting in loosening. Nonetheless, the absence of a difference in loosening torque ratio before and after testing may be because no tensile force was applied to the screw, and there was no plastic deformation. It was, however, difficult to identify plastic deformation from SEM images in the present study; it may be necessary in the future to perform CT scans of screws before and after tests, and then superimpose the DICOM data to detect where the screws are deformed.

#### *Abutment screws used for zirconia implants*

When a screw is tightened, a frictional force occurs at the contact surface of the screw, and shear stress due to the torsional torque and axial stress caused by the axial force are applied to the screw<sup>29)</sup>. Kanbara *et al.*<sup>5)</sup> reported that in wear tests on pure titanium and Ti-6Al-4V, abrasive wear was caused by Y-TZP. Therefore, abutment screws for zirconia implants should be fabricated out of zirconia. However, since Kikuchi<sup>30)</sup> found that zirconia has a fracture toughness of 5–20 MPa·m<sup>1/2</sup> while the value for titanium is 66 MPa·m<sup>1/2</sup>, and assuming that a tensile force is applied to the screw, as in the present study, a high fracture toughness would also be needed. Abutment screw materials for zirconia implants should therefore preferably have a strength close to that of zirconia, and also a high fracture toughness.

### CONCLUSIONS

Within the limitations of the present study the following conclusions were obtained:

1. The pure titanium screws showed more loosening than the titanium alloy screws.
2. The combinations of zirconia blocks and pure titanium screws showed more screw loosening when tests were performed at the eccentric point, located 9 mm from the center of the screw hole, than at the centric point, located 3 mm from the center of the screw hole.
3. There was no difference in screw loosening before and after testing at the centric point.
4. For all groups, scratches and wear occurred on the contact surface of the screw after tightening; the extent of this damage did not change after testing.

### ACKNOWLEDGMENTS

We wish to thank NANTOH, who provided the test samples in the present study, and everyone in the

Department of Crown and Bridge Prosthodontics, The Nippon Dental University School of Life Dentistry at Niigata, who cooperated with this research.

### REFERENCES

- 1) Goodacre CJ, Bernal G, Rungcharassaeng K, Kan JY. Clinical complications with implants and implant prostheses. *J Prosthet Dent* 2003; 90: 121-132.
- 2) Avivi-Arber L, Zarb GA. Clinical effectiveness of implant-supported single-tooth replacement: the Toronto Study. *International J Oral Maxillofac Implants* 1997; 11: 311-321.
- 3) Siamos G, Winkler S, Boberick KG. The relationship between implant preload and screw loosening on implant-supported prosthesis. *J Oral Implantol* 2002; 28: 67-73.
- 4) Siadat H, Pirmoazen S, Beyabanaki E, Alikhasi M. Does abutment collar length affect abutment screw loosening after cyclic loading? *J Oral Implantol* 2015; 41: 346-351.
- 5) Kanbara T, Yajima Y, Yoshinari M. Wear behavior of tetragonal zirconia polycrystal versus titanium and titanium. *Biomed Mater* 2011; 6: 021001.
- 6) Jemt T, Lekholm U, Gröndahl K. A 3-year followup study of early single implant restorations ad modum Brånemark. *Int J Periodontics Restorative Dent* 1990; 10: 340-349.
- 7) Jemt T, Pettersson P. A 3-year follow-up implant treatment. *J Dent* 1993; 21: 203-208.
- 8) Kose OD, Karatasli B, Demircan S, Kose TE, Cene E, Aya S, Erdem AM, Cankaya AB. In vitro evaluation of manual torque values applied to implant-abutment complex by different clinicians and abutment screw loosening. *Biomed Res Int* 2017; 7376261.
- 9) Katsuta Y, Watanabe F. Abutment screw loosening of endosseous dental implant body/abutment joint by cyclic torsional loading test at the initial stage. *Dent Mater J* 2015; 34: 896-902.
- 10) Alencar MM, Bastos L, Verde L, Moura WL De, Dolores C, Soares V. FEA of peri-implant stresses in fixed partial denture prosthesis with cantilevers. *J Prosthodont* 2017; 26: 150-155.
- 11) Cionca N, Hasim D, Mombelli A. Zirconia dental implants: where are we now, and where are we heading? *Periodontol* 2000 2017; 73: 241-258.
- 12) Payer M, Heschl A, Koller M, Arnetzl G, Lorenzoni M, Jakse N. All ceramic restoration of zirconia two-piece implants-a randomized controlled clinical trial. *Clin Oral Implants Res* 2015; 26: 371-376.
- 13) Cionca N, Müller N, Mombelli A. Two piece zirconia implants supporting all-ceramic crowns: A prospective clinical study. *Clin Oral Implants Res* 2015; 26: 413-418.
- 14) Siddiqi A, Khan AS, Zafar S. Thirty years of translational research in zirconia dental implants: A systematic review of the literature. *J Oral Implantol* 2017; 43: 314-325.
- 15) Pieralli S, Kohal RJ, Jung RE, Vach K, Spies BC. Clinical outcomes of zirconia dental implants: A systematic review. *J Dent Res* 2016; 96: 38-46.
- 16) Kirov D, Stoichkov B. Factors affecting the abutment screw loosening. *J IMAB* 2017; 23: 1505-1509.
- 17) Kourtis S, Damanaki M, Kaitatzidou S, Kaitatzidou A, Roussou V. Loosening of the fixing screw in single implant crowns: predisposing factors, prevention and treatment options. *J Esthet Restor Dent* 2017; 29: 233-246.
- 18) Lee CK. Evaluation of test protocol variables for dental implant fatigue research. *SoDM Masters Theses* 2007: 149.
- 19) Farooq M, Sazonov E. Automatic measurement of chew count and rate during food intake. *Electronics* 2016; 5: 62.
- 20) Fernandes FMT, Sathler R, Natalicio LG, Henriques CFJ, Pinzan A. Comparison of mesiodistal tooth widths in Caucasian, African and Japanese individuals with Brazilian

- ancestry and normal occlusion. *Dent Press J Orthod* 2013; 18: 130-135.
- 21) Kim Y, Oh TJ, Misch CE, Wang HL. Occlusal considerations in implant therapy: clinical guidelines with biomechanical rationale. *Clin Oral Implants Res* 2005; 16: 26-35.
- 22) Mericske-Sterm R, Zarb GA. In vivo measurements of some functional aspects with mandibular fixed prostheses supported by implants. *Clin Oral Implants Res* 1996; 7: 153-161.
- 23) Hill EE, Phillips MS, Breeding CL. Implant abutment screw torque generated by general dentists using a hand driver in a limited access space simulating the mouth. *J Oral Implantol* 2007; 33: 277-279.
- 24) Yoshida K. The research of developing allergy-considered micro screw for medical and dental use. [Translated from Japanese.] Report of grant-supported researches The Amada foundation 2012; 25: 129-132.
- 25) Moraes LM, Henrique P, Rossetti O, Maria L, Rossetti N, Bonachela WC. Marginal fit at cylinder-abutment interface before and after overcasting procedure. *J Appl Oral Sci* 2005; 13: 366-371.
- 26) Kohal RJ, Finke CH, Klaus G. Stability of prototype two-piece zirconia and titanium implants after artificial aging: An in vitro study. *Clin Implant Dent Relat Res* 2009; 11: 323-329.
- 27) Yanagida H, Islam N, Sato Y, Kitagawa N, Uchida K. Influence of implants diameter on maximum resistant load. *Dent Med Res* 2009; 29: 128-133.
- 28) Osman BR, Swain MV. A critical review of dental implant materials with an emphasis on titanium versus zirconia. *Materials* 2015; 8: 932-958.
- 29) Fukuoka T. Mechanics and practical of bolt fastening. [Translated from Japanese.] *J JIME* 2011; 6: 119-125.
- 30) Kikuchi M. Development of titanium alloys for dental CAD/CAM systems.[in Japanese] *Ann Kagoshima Dent* 2014; 34: 41-51.